

Product Information

Periphery module

PM DI16



(valid from 06/2012)

Description

compact periphery module for 16 digital inputs 24V

- green diagnostic LED for each input
- insertion stripe with description field for every signal
- cage-clamp connector with self-lock and 2 lift arms

Application with 2-wire switches

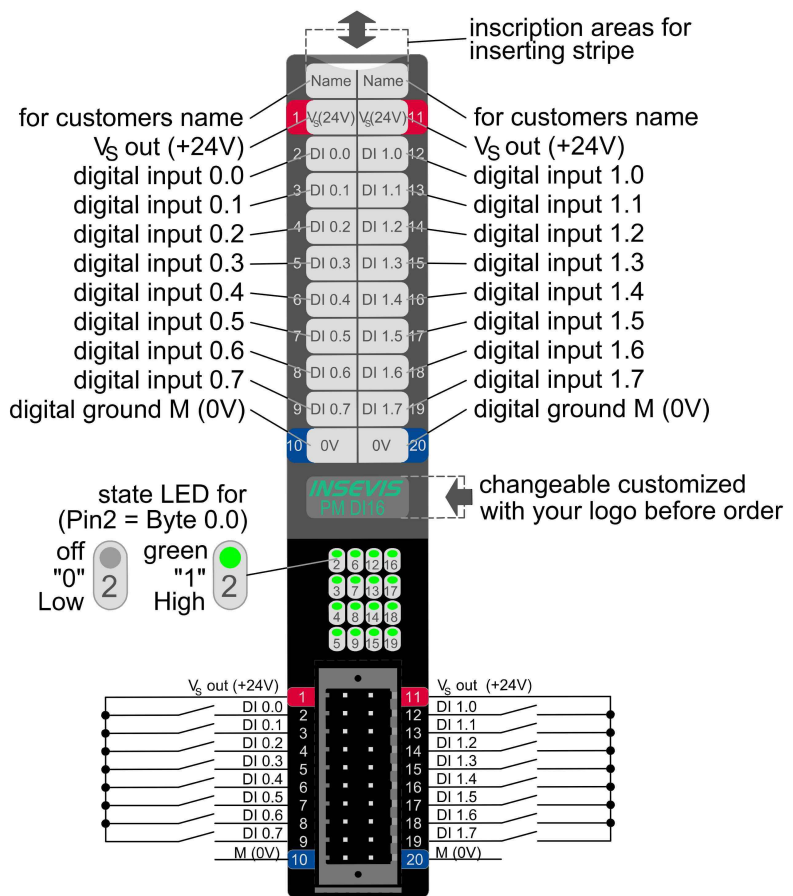

Figure above: Description and wiring of all connections of periphery module DI16

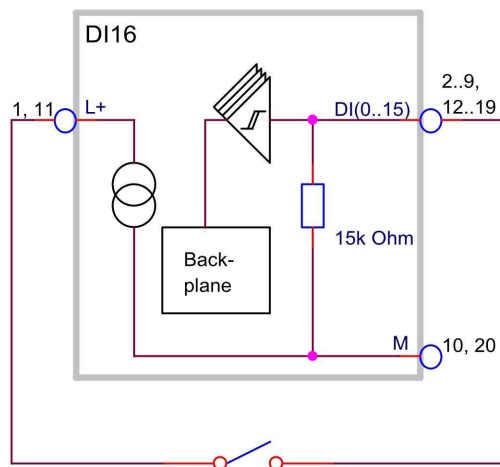

Figure above: Block diagram of DI16 for 2 wire switches

Input	
Start address:	<input type="text" value="0"/>
End address:	<input type="text" value="1"/>
Output	
Start address:	<input type="text" value="0"/>
End address:	<input type="text" value="0"/>

Figure above: Configuration block of start-/end addresses of DI16-inputs (in byte) in the ConfigStage

Description

compact periphery module for 16 digital inputs 24V

- green diagnostic LED for each input
- insertion stripe with description field for every signal
- cage-clamp connector with self-lock and 2 lift arms

Application with 3- / 4-wire switches

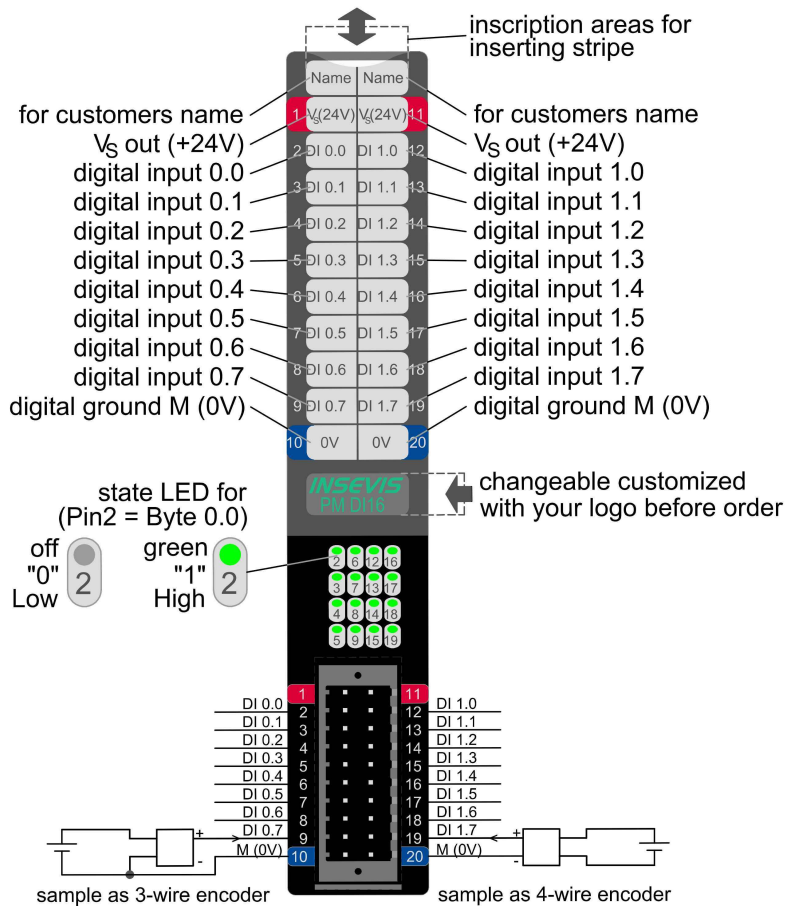
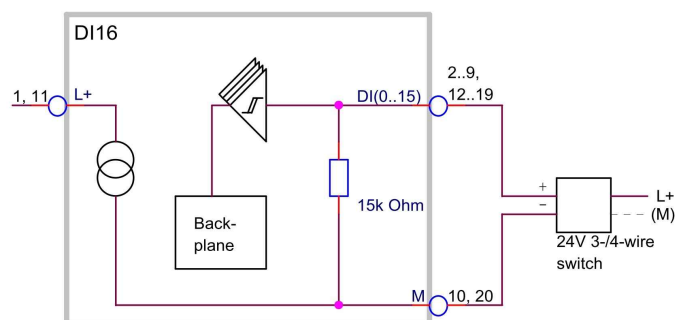

Figure above: Description and wiring of all connections of periphery module DI16





left: Block diagram of DI16 for 3- and 4-wire switches

Input	
Start address:	<input type="text" value="0"/>
End address:	<input type="text" value="1"/>
Output	
Start address:	<input type="text" value="0"/>
End address:	<input type="text" value="0"/>

left: Configuration block of start-/ end addresses of DI16-inputs (in byte) in the ConfigStage

Technical data	
Dimensions W x H x D (mm) Weight	20 x 108 x 70 mm ca. 150 g
Operating temperature range Storage temperature range	-20°C ... +60°C (no condensation) -30°C ... +80°C
Connection technology	unlockable connector with self-lock and 2 lift-arms (cage clamp technology) for cross section up to max. 1mm ²
Sensor supply Load voltage L+	short circuit proof output, current limited to 30 mA (typ.) 24V DC (11V ... 30V DC, is connected by device supply)
Wire length unshielded (max.) shielded (max.)	30 m 100 m
Digital inputs Diagnostic LEDs	16 16, green
Input voltage for signal 0 for signal 1	0V ... +5 V +7,5V ... +30 V
Input current for signal 1	1 mA
Broken wire detection Potential separation to PLC Access of 2-wire-BERO	no no no
Input delay Output delay Sampling cycle time	150 µs (typ.) 350 µs (typ.) as onboard modul on the PLC = cycle synchronous

Documentation and samples

	web:	www.insevis.com		web:	www.insevis.com
	register:	Products / Periphery		register:	Service
	download:	TI-PM xxxx.pdf		register:	Periphery
	register:	Documentation		It will be provided documented samples for all functions to be downloaded free of charge.	
download:	Manual Periphery.pdf				

Ordering data module

Identification	Order-no.	Packaging unit
Periphery module DI16	PM-DI16-02	PU: 1 piece

Ordering data accessoires

Identification	Order-no.	Packaging unit
Connector 2x10pin	E-CON20-00	PU: 1 piece
Inserting stripe for description fields, 2x11 fields *	E-LABES22-00	PU: 20 pieces
Inserting stripe V for logo and identification for rear side	E-LABV-00	PU: 100 pieces

* (1x already part of first deliveries scope)

Copyright

This and all other documentation and software, supplied or hosted on INSEVIS web sites to download are copyrighted. Any duplicating of these data in any way without express approval by INSEVIS GmbH is not permitted.

All property and copy rights of these documentation and software and every copy of it are reserved to INSEVIS GmbH.

Trade Marks

INSEVIS refers that all trade marks of particular companies used in own documentation as e.g.

- STEP®, SIMATIC® and other as reserved trade mark of SIEMENS AG.

- CANopen® and other as reserved trade mark of CAN in Automation eG

and more reserved trade marks are property of the particular owners and are subjected to common protection of trade marks.

Disclaimer

All technical details in this documentation were created by INSEVIS with highest diligence. Anyhow mistakes could not be excluded, so no responsibility is taken by INSEVIS for the complete correctness of this information. This documentation will reviewed regularly and necessary corrections will be done in next version.

With publication of this catalog all other versions are no longer valid.